

# ISIMET

## S – Series Rack Assembly Installation, Maintenance, and Operation Instructions

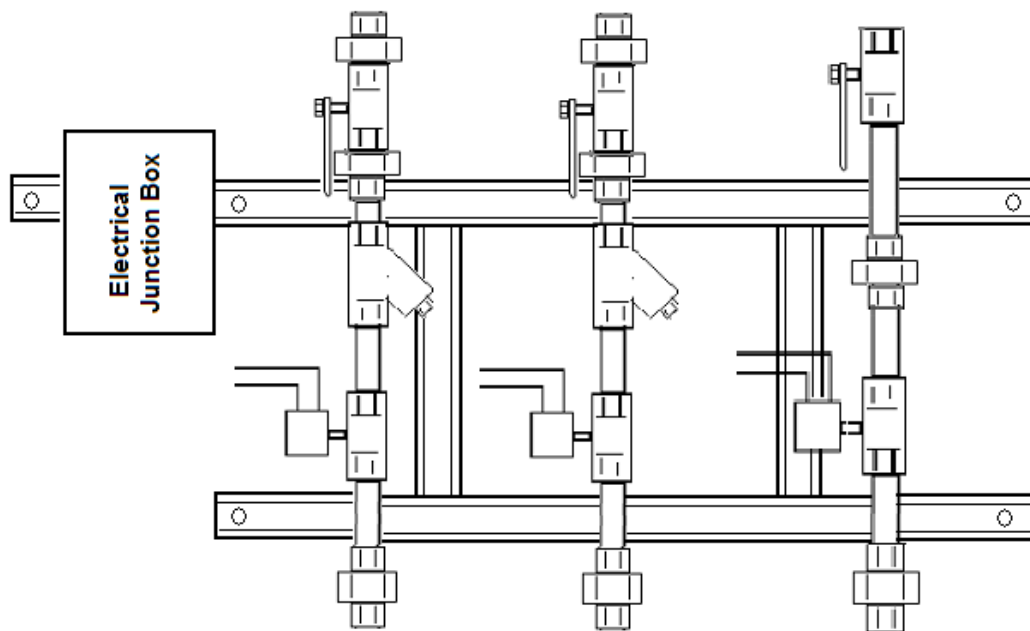

The Rack Assembly is a pre-assembled valve assembly mounted on galvanized strut. Wiring leads from the solenoids terminate at the junction box. The assembly is intended for use with the *ISIMET* Utility Controller. The installation and mounting procedures described in this manual are intended as a reference guide for recommended techniques. This manual is not intended to prevent alternative means of installation of the unit where specific engineered design criteria mandates alternate methods of installation.

## ***ISIMET***

Rack Assembly  
Installation, Maintenance, and Operations Instructions

Copyright © 2014 ***ISIMET***, LLC.  
All rights reserved.

This document is copyrighted. This document may not, in whole or part, be copied, duplicated, reproduced, translated, electronically stored, or reduced to machine readable form without prior written consent from ***ISIMET***, LLC.

Although the material contained herein has been carefully reviewed, ***ISIMET***, LLC does not warrant it to be free of errors or omissions. ***ISIMET*** reserves the right to make corrections, updates, revisions, or changes to the information contained herein.

***ISIMET*** is a trademark of ***ISIMET***, LLC.

### **Warranty:**

***ISIMET*** will repair or replace any defective parts or workmanship of this product for the designated period from date of installation. Damage caused by incorrect installation or improper usage is not warranted. Failure to follow recommended installation, operation, and/or maintenance procedures listed in this manual may void product warranty. Recovery rights shall be limited to the total sum of the amounts paid for the product by the purchaser.

***ISIMET*** warrants the solenoid to be free from defects in materials or workmanship when incorporated into an ***ISIMET*** Control System for a period of one hundred and eighty (180) days from the date of installation by buyer otherwise, for a period of ninety (90) days. Where the ***ISIMET*** Controller is operated by a time sequence device for shutdown during non-use periods the warranty for solenoids is extended to one year. Power should be turned off to solenoids when utilities are not in service.

**General Service Solenoids:** ***ISIMET*** cannot warrant against the effects of hard water, corrosive agents, contaminants, or debris present in the piping system or against effects of exotic or harsh substances.

Damage caused by incorrect installation or improper usage is not warranted. Failure to follow recommended installation, operation, and/or maintenance procedures listed herein may void product warranty. Recovery rights shall be limited to the total sum of the amounts paid for the product by the purchaser.

If the equipment or any part thereof becomes defective within the warranty period, the defective equipment will be replaced or credit allowed therefore at the sole option of ***ISIMET***, but without credit or payment for any labor.

### **Limits of Liability:**

***ISIMET***'s liability shall be limited to costs of repair or replacement parts. The Laboratory Service Panel and Utility Controller are not intended for usage other than those expressly described in this manual. ***ISIMET*** shall not be liable for damage or injury caused by the improper use of the product.

***ISIMET*** does not warrant against or assume liability for failure of operation or lack of notification to secondary integrated monitoring systems. The system should be thoroughly tested and adjustments made at time of initial operation. Periodic testing should be conducted by the user to assure that all components function and operate according to specifications.

Care should be taken in the installation of this product. ***ISIMET*** shall not be liable for damage or injury caused from the improper installation of the product.

Warranty is Subject to Compliance with Specific Installation Requirements.

### **DISCLAIMER OF IMPLIED WARRANTY:**

**THERE ARE NO WARRANTIES THAT EXTEND BEYOND THE DESCRIPTION HEREIN. SELLER DISCLAIMS ANY IMPLIED WARRANTY OF MERCHANTABILITY OF THE GOODS OR OF THE FITNESS OF THE GOODS FOR ANY PURPOSE, AND BUYER AGREES THAT THE GOODS ARE SOLD "AS IS."**

Printed in the United States of America.

<b>Table of Contents:</b>	
	<u>Page</u>
Warranty.....	2
Caution and Fuse Statements .....	3
Model Numbers.....	4
Specifications.....	4
Solenoid Valve Product Numbers.....	5
Solenoid Specifications & Wiring Information.....	6
Ball Valve Specifications.....	6
Piping Connections .....	7
Testing and Cleaning the Piping System.....	7
Special Arrangement and Placement of the Enclosure..	7
Routine Maintenance.....	8

**Caution:**

Pressure testing for fuel gas system solenoids should not exceed 15 psi at the body of this valve due to potential damage caused by excessive pressure applied to the diaphragm. Coils should not be energized unless secured to the valve core. Coils will heat during operation. A temperature of  $\pm 150^{\circ}$  is not uncommon.

**General Service Solenoids:** Where adverse or harsh operating conditions exists in the water system such as the presence of hard water, then it is recommended that only Series 200 Solenoids with 12-VDC latching coils be utilized and that an extensive routine operating and maintenance program be developed by the end user to counter the effects of these conditions. Where operation of water containing corrosive agents, exotic or harsh mediums are intended for control by solenoid then verify application prior to installation. ISIMET cannot warrant against the effects of hard water, corrosive agents, contaminants, or debris present in the piping system or against effects of exotic or harsh substances. If specific operation conditions are in doubt, contact ISIMET prior to installation.

**Wiring Information and Instructions:** Assemblies having 24 VAC and 120 VAC coil voltage where ISIMET provides control are provided with solenoid leads terminated at a multi-post terminal block. Assemblies having 12 VDC coils without 120 VAC provided require an additional 12 VAC wire from the ISIMET control unit. Terminal posts are labeled to correspond with output circuits from a Utility Controller. Minimum wire sizing is 18 AWG. Assemblies having 120 VAC coil voltage for use with a Utility Controller with 24 VAC control are provided with Model # RIBMN24S panel mounted relay within a J-Box. Solenoid leads are connected to a contact output terminal at each relay. Each relay is labeled to correspond with output circuits from the Utility Controller. A terminal block is provided in the J-Box for field wiring to 120 VAC line voltage. Refer to schematic provided in the unit for units having 120 VAC coils with either control from other sources or 24 VAC control.

**Caution:** Only connect 24 VAC control wiring from Utility Controller output circuits to input terminal at relays where coils are 120 VAC & control is 24 VAC. Grounding: 120 VAC assemblies should be grounded by terminating service ground wire at grounding lug located within the J-Box.

**All local codes must be followed when installing this unit and connecting the conduit to the service panel and making wiring connections. Do not install wiring or cable for integrated systems, remote panic assemblies or other interface wiring within conduit for either 24-vac control or 120-vac line voltage. Each wiring system should be housed in independent conduit and not bundled with wiring for other systems.**

**Caution:** Connect appropriate control wiring from Utility Controller output circuits to input posts at terminal. Where reset fuses are provided at control circuitry for solenoid, having the fuse tripped indicates a malfunction in the operation of the solenoid. Service the solenoid to determine cause of failure, correct problems immediately. Do not bypass reset fuses in circuit.

**Notes:** Only qualified craftsmen licensed within the governing jurisdiction to perform the work associated with this installation should install and/or service this equipment.

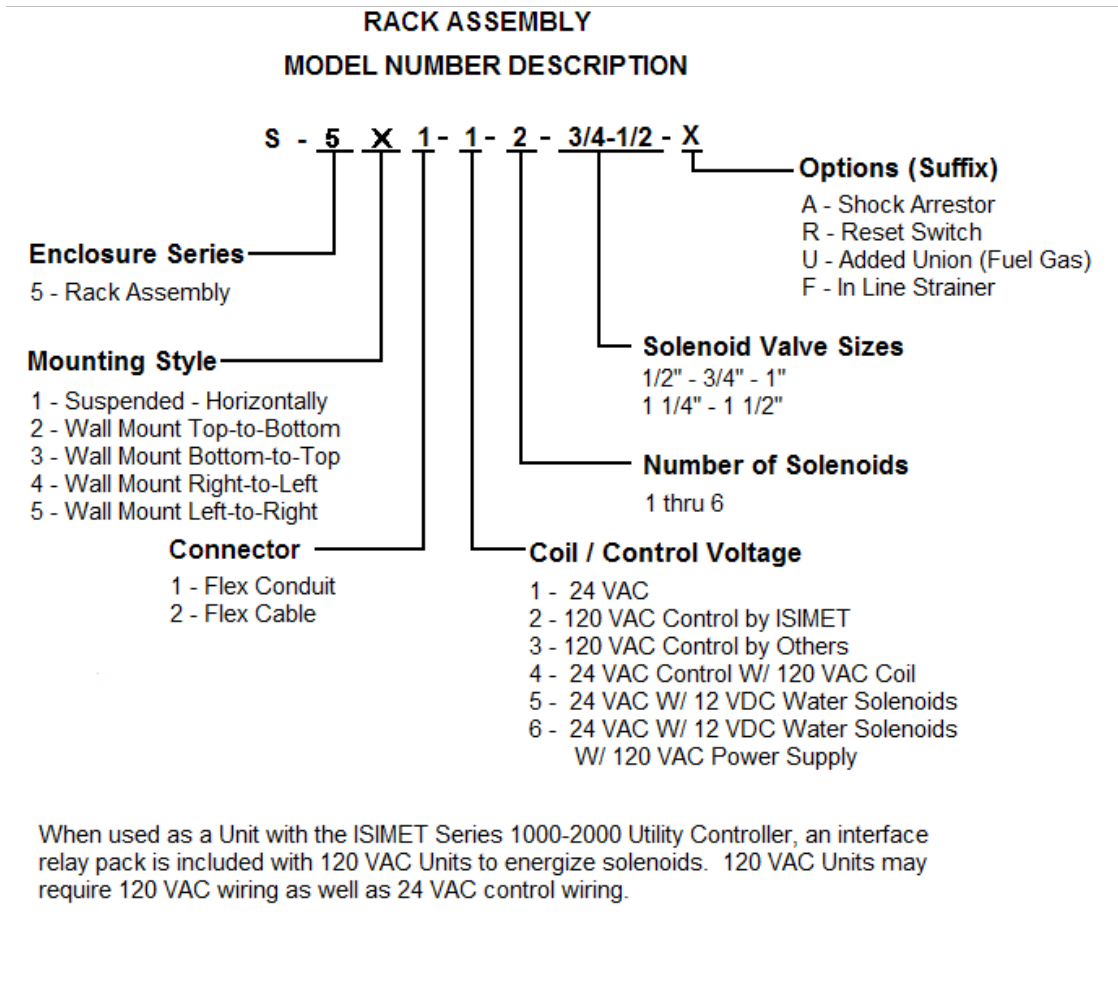

### Rack Assembly Configuration and Typical Mounting:

The image of the Rack Assembly is generic and may not represent the actual assembly provided with this manual. Valves are arranged on the rack per specifications provided at the time of order.

To suspend the Rack from structural members:

Determine the position the Rack as required and measure distances from the rack's strut to secure structural members located above the rack. Measure the distance from the strut to the member allowing for needed thread makeup. Determine appropriate size and type of all-thread rod. Cut rods, four (4) minimum, and prepare ends. Securely attach rods at rack and structural member using industry approved hardware and methods.

To mount the Rack vertically to a wall surface:

Position the Rack as required and mark wall surface for holes to be drilled in order to secure the Rack. Setting aside the Rack, drill holes and insert appropriate mounting hardware. Reposition the Rack and affix to the wall surface using appropriate hardware.

**CAUTION:** The structural member and/or wall to which the Rack Assembly is to be suspended or mounted should be of sufficient strength to support the entire weight of the Rack, connected piping and mounting hardware. All mounting hardware is field provided. Suspension and/or mounting means and methods should meet the most stringent of industry standards as well as comply with project specific requirements.

## Solenoid Specifications

ISIMET Model	Port Size (in)	Orifice Size (in)	Seat Material	Min. Pressure Diff.	Flow Fact or Cv	Operation Pressure		24/60 VAC		120/60 VAC	
						Air/Gas psi	Water psi	VA Inrush Holding	VA	VA Inrush Holding	VA
S-201	1/2	.5	NBR	2	4.8	230	230	25	14.5	25	14.5
S-202	3/4	.75	NBR	2	9.8	230	230	25	14.5	25	14.5
S-203	1	1	NBR	2	14	230	230	25	14.5	25	14.5
S-204	1 1/4	1.375	NBR	2	28	150	150	25	14.5	25	14.5
S-205	1 1/2	1.5	NBR	2	36	150	150	25	14.5	25	14.5
S-206	2	2	NBR	2	53	150	150	25	14.5	25	14.5
S-208	3	3	BUNA	3	77	225	225	-	-	45	27
S-222	3/4	3/4	FKM/NSF	2	9.8	230	230	25	14.5	25	14.5
S-223	1	1	FKM/NSF	2	14	230	230	25	14.5	25	14.5
S-224	1 1/4	1 3/8	FKM/NSF	2	28	150	150	25	14.5	25	14.5
S-225	1 1/2	1 1/2	FKM/NSF	2	36	150	150	25	14.5	25	14.5
S-301	1/2	.71	BUNA	0	4.0	3	171,600 *	45	27	45	27
S-302	3/4	.71	BUNA	0	4.9	3	241,500 *	45	27	45	27
S-303	1	1.26	BUNA	0	1.2	0.75	635,500 *	45	27	45	27
S-304	1 1/4	1.26	BUNA	0	14	0.75	762,700 *	45	27	45	27
S-305	1 1/2	1.89	BUNA	0.015	41	3	2,225,530 *	45	27	45	27
S-306	2	2.0	BUNA	0.015	50	3	2,732,994 *	45	27	45	27
S-308	3	3	NITRILE	0	93.6	45	5,188,000 *	-	-	113	113
S-401	1/2	.5	NBR	2	4.8	230	230	25	14	25	14
S-402	3/4	.75	NBR	2	9.8	230	230	25	14	25	14
S-403	1	1	NBR	2	14	230	230	25	14	25	14
S-501	1/2	.5	BUNA	3	4.2	225	225	12.9	8	-	-
S-502	3/4	.63	BUNA	3	6.4	225	225	12.9	8	-	-
S-503	1	1	BUNA	4.5	10.5	225	225	12.9	8	-	-
S-601	1/2	.625	NBR	0	2.8	TORR@.003	MERC @.00039	25	14.5	25	14.5
S-602	3/4	.625	NBR	0	2.8	TORR@.003	MERC @.00039	25	14.5	25	14.5
S-603	1	1	NBR	0	8.3	TORR@.003	MERC @.00039	25	14.5	25	14.5
S-605	1 1/2	1.89	BUNA	.15	41	TORR@.005	MERC @.00039	45	27	45	27
S-606	2	2.0	BUNA	.15	50	TORR@.005	MERC @.00039	45	27	45	27
S-702	3/4	.75	FKM	0	7	105	-	-	-	267	80
S-703	1	1.02	FKM	0	12	105	-	-	-	267	80
S-705	1 1/2	1.26	FKM	0	18	105	-	-	-	267	80
S-706	2	1.50	FKM	0	27	105	-	-	-	267	80
S-801	1/2	.55	FKM	0	3.1	105	105	57	23	57	23
S-802	3/4	.71	FKM	0	5.03	105	105	57	23	57	23
S-803	1	1.02	FKM	3	13	225	225	45	27	45	27
S-805	1 1/2	1.50	FKM	3	29	225	225	45	27	45	27
S-806	2	1.97	FKM	3	47	225	225	45	27	45	27
S-811	1/2	.55	BUNA	0	3.1	105	105	57	23	57	23
S-812	3/4	.71	BUNA	0	5.03	105	105	57	23	57	23
S-813	1	1.02	BUNA	3	13	225	225	45	27	45	27
S-815	1 1/2	1.50	BUNA	3	29	225	225	45	27	45	27
S-816	2	1.97	BUNA	3	47	225	225	45	27	45	27
S-822	3/4	.79	BUNA	3	5.9	225	225	45	27	45	27
S-823	1	1.02	BUNA	3	13	225	225	45	27	45	27
S-825	1 1/2	1.50	BUNA	3	29	225	225	45	27	45	27
S-826	2	1.97	BUNA	3	47	225	225	45	27	45	27
S-832	3/4	.79	PTFE	7.5	5.9	255	-	45	27	45	27
S-833	1	1.02	PTFE	7.5	13	255	-	45	27	45	27
S-835	1 1/2	1.5	PTFE	7.5	29	255	-	45	27	45	27
S-836	2	1.97	PTFE	7.5	47	255	-	45	27	45	27

- \*BTU @ 0.60 Specific Gravity W/pressure drop of 0.5inch water column
- Vacuum is rated @ TORR and inches of Mercury
- For Stainless Steel – Refer to S-200 Series Specifications

### **Solenoid Valve Specifications:**

Series 200 are Brass General Service NPT, Normally Closed 2 psi differential Solenoid Valves.

Series 200-SS are Stainless Steel General Service NPT, Normally Closed 2 psi differential Solenoid Valve.  
(Use 200-SS for lead free applications where lead free solenoids are not available.)

Series 220 are Lead Free Brass General Service NPT, Normally Closed 2 psi differential Solenoid Valves.  
(Series 200 and 220 Solenoids are available W/ DC Latching Coils for use in Water Piping Systems)

Series 300 are Fuel gas, Aluminum construction Normally Closed Solenoid Valves.  
(Designed for low pressure fuel gas applications.)

Series 400 are Brass General Service NPT, Normally Open 2 psi differential Solenoid Valves.  
(Intended for use as Bypass Valves in Circulated Hot Water Systems.)

Series 500 are Brass General Service NPT, Low Wattage, Normally Closed 3– 4.5 psi differential Solenoid Valves.

Series 600 are Brass thru 1" & Aluminum 1 1/2"-2" NPT, Normally Closed Solenoid Valves for Vacuum Systems.  
(Suitable for Medium to Fine Vacuums only.)

Series 700 are Bronze NPT, Normally Closed Solenoid Valves for Fuel Oil Systems.

Series 800 are Brass NPT, Normally Closed Solenoid Valves for Oxygen, Acetylene, Argon, and CO2 Systems.

Series 810 are Brass NPT, Normally Closed Solenoid Valves for Hydrogen Systems.

Series 820 are Brass NPT, Normally Closed Solenoid Valves for Hi Pressure Gas Systems.

Series 830 are Brass NPT, Normally Closed Solenoid Valves for Helium Systems.

General Service Solenoids: Where adverse or harsh operating conditions exists in the water system such as the presence of hard water, then it is recommended that only Series 200 Solenoids with 12-VDC latching coils be utilized and that an extensive routine operating and maintenance program be developed by the end user to counter the effects of these conditions. Where operation of water containing corrosive agents, exotic or harsh mediums are intended for control by solenoid then verify application prior to installation. ISIMET cannot warrant against the effects of hard water, corrosive agents, contaminants, or debris present in the piping system or against effects of exotic or harsh substances. If specific operation conditions are in doubt, contact ISIMET prior to installation.

Maximum operating temperature for the solenoid is 180° F / 82.2° C

Coil Rating: Continuous duty totally encapsulated. Voltage Tolerances: +10%, - 10% of applicable voltage.

All Solenoid Standard Coils have a NEMA 1 Rating. Some valves are available as weather resistant and/or explosion proof.

DC Latching Coils are intended for use in applications where the presence of hard or corrosive water is anticipated to cause premature failure in the operation of the valve or where the ON operation of the solenoid is anticipated to extend for long periods without anticipated water flow. Where no 120 VAC wiring is provided at the unit then an additional control wire from the ISIMET control unit will be required to transmit the needed 12 VAC operating/control signal.

### **Ball Valve Specifications:**

**Apollo or Nibco** Bronze 2-Piece Ball Valve. (or equivalent)

All valves are full port, bronze

Valve Station Suffix:

"TUT" – General Service Double -Threaded Union (Through 1") **600 psi CWP MSS SP-110**

"TU" – General Service Threaded Union **150 psi SWP 600 psi CWP MSS SP-110**

"XU" – Non-Union **150 psi SWP 600 psi CWP MSS SP-110**

"FB" – General Service Non-Union W/ integral 20 mesh strainer (Jomar Mfg.) (1/2" – 2") **150 psi WSP 400 psi WOG**

**FB & TUT Non Lead Free only – TUT will be phased out by Mid-Summer**

Valves for fuel gas systems are UL Listed but are not available with the integral output union or strainers (XU) only.

Valves greater than 2" only available in "XU"

**Recommend the use of Series 220 for all domestic water systems.**

**1/2" & 2" Lead Free Solenoids are Currently Not Available. Recommend use of S-200-SS for these applications.**

**S-301 – S-304 & S-308 are 0 Differential; S-305 & S-306 are 0.015 psi Differential.**

**Caution should be used if S-305 and S-306 solenoids are used in science lab applications.**

### Piping Connections:

When making service piping connections, provide back-up restraint at the assembly so as to prevent the turning of the valve assemblies. Disrupting the factory piping connections may cause leakage.

The assemblies are mounted on welded galvanized strut using nylon pipe clamps in order to prevent harmonic hum from resonating through the corresponding piping systems and building structure.

### Testing & Cleaning the Piping System:

The piping system should be thoroughly tested and cleaned of all foreign matter and debris prior to placing the valve and piping systems into service. Unions are provided loose fit. Inlets and outlets are plugged to prevent debris from entering the piping assembly.

The piping joints on the Rack Assembly should be tested to assure tight connections. Do not exceed 15 psi test on any fuel gas system solenoid from upstream. Damage to the coil may result when first energized if testing is greater than 15 psi.

**Caution:** All local codes and regulations should be followed when installing the assembly and making the piping connections.

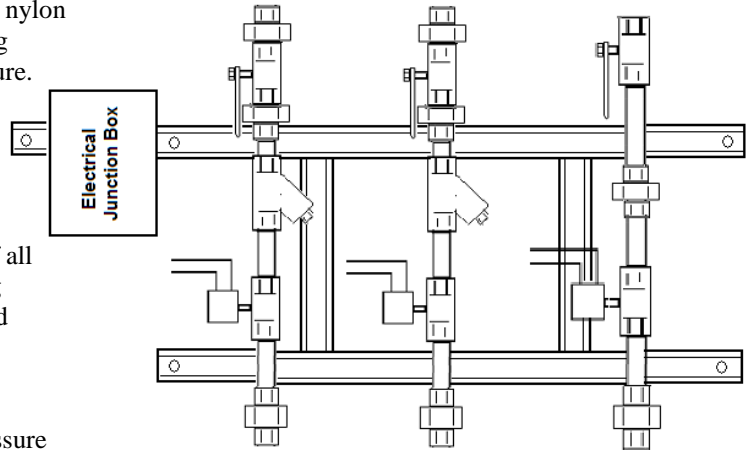

### Special Placements and Arrangement of the Rack Assembly:

The use of industry standard support assemblies including threaded rod, strut channel and structural angle is recommended when supporting the Rack Assembly by means other than described previously in this manual. *ISIMET* recommends that good industry practices be followed and that the support of the Rack Assembly and integral piping assemblies be separate from the support of the field installed piping systems. Do not support the Rack Assembly directly from the connected piping. Installation should not inhibit access to the valve assemblies for the purpose of routine maintenance.

For convenience of the installation of the specific project requirements, the piping assemblies may be removed and reversed. Solenoids should be turned to a horizontal or vertical position where coils are not inverted. Care should be taken in the removal and replacement of the assemblies to assure that wiring is not damaged or that the piping connections are not loosened.

Other arrangements not specifically stated herein are restricted unless certified in writing from *ISIMET*. Specifically, the solenoid body cannot be mounted so that the solenoid coil rests in a downward or inclined position. Placing into operation a solenoid in this position may foul the diaphragm or orifice and prevent proper operation of the valve. Submit shop drawings or photographs in order to verify alternate installation techniques.

3" Solenoids **MUST** be mounted so that the coil rests in a full upright position.

### Notice:

**Piping system should be thoroughly flushed prior to operation. If systems are operated without proper flushing, the solenoid diaphragm may become fouled and may not close properly when solenoid coil is disengaged. ISIMET recommends providing in-line strainers immediately upstream of the solenoid for all fluid delivery systems, and where debris or harsh conditions are anticipated. ISIMET also recommends that shock arrestors be provided where water hammer is anticipated or when stated in the project specifications.**

**Routine Maintenance:**

Periodic examination and testing of the piping system should be performed to assure that the solenoids are functioning properly and that no foreign debris has lodged in the solenoid valve orifice, preventing the proper operation of the valve.

**CAUTION:**

**ISIMET DOES NOT** recommend that service to emergency and/or safety devices, such as emergency showers and eyewashes, be controlled by the Utility Controller System or Solenoids. Such devices are intended to operate independent of restrictive authority operation as is the case with the design of this unit. Power to the solenoids should be turned OFF when utilities are not in service.

**ISIMET** makes available components for the monitoring of such safety devices. Please contact **ISIMET** regarding any questions regarding this type of application.



**ISIMET, LLC**

**103 W. CJ Wise Parkway  
PO Box 129 (Mailing)  
Naples, TX 75568**

**Phone (866) 897-0737  
Fax (903) 897-0740**

**[www.ISIMET.com](http://www.ISIMET.com)**